

to the  $N^{14}$  7.03  $\rightarrow$  0 transition rather than to the  $C^{14}$  7.01  $\rightarrow$  0 transition. Further evidence for this assignment is that the  $N^{14}$  7.03-MeV is known to be excited by the  $C^{13}(d,n)N^{14}$  reaction at  $E_d=3.9$  MeV,<sup>26</sup> and is known to decay predominantly by a ground-state transition.<sup>5</sup> On the other hand, the  $C^{14}$  7.01-MeV level was not observed in a study of the  $C^{13}(d,p)C^{14}$  reaction at  $E_d=14.8$  MeV,<sup>23</sup> while all the other bound levels were. Although no quantitative numbers are available we can say that at  $E_d=14.8$  MeV the  $C^{14}$  7.01-MeV level must be quite weakly excited compared to the other  $C^{14}$  levels. Insofar as the  $C^{13}(d,p)C^{14}$  reaction proceeds by the stripping mechanism, the same should be true at lower deuteron energies and this is inconsistent with the rather large cross section (see Fig. 5) observed for the 7.03-MeV pair line. If, however, the  $C^{14}$  7.01-MeV level has  $J^\pi=0^+$  and the 7.03-MeV pair line were due to a ground state transition from this level, the cross section for the 7.03  $\rightarrow$  0 transition would be about 500 times less<sup>9</sup> and the above remarks would not apply. A  $0^+$  assignment was made to the  $C^{14}$  7.01-MeV level from a fit to the  $C^{12}(t,p)C^{14}$  angular distribution,<sup>11</sup> but we believe this assignment should not be taken as definite and, in fact, there is strong indirect evidence that the  $C^{14}$  7.01-MeV level is  $J^\pi=2^+$ . An  $L=0$  (and thus  $J^\pi=0^+$ ) double-stripping pattern gives the best fit to the  $C^{12}(t,p)C^{14}$  (7.01-MeV level) reaction<sup>11</sup> with an  $L=2$  (and thus  $J^\pi=2^+$ ) pattern giving the second best fit.<sup>12</sup> The  $L=2$  pattern fits the maximum of the angular distribution but has a larger half-width than the experimental data. In view of the possibilities for distortion and the lack of agreement between the simple double-stripping theory and experiment in many cases,<sup>27</sup> we

<sup>26</sup> R. E. Benenson, Phys. Rev. **90**, 420 (1953).

<sup>27</sup> See, for instance, Ref. 18.

feel that the double-stripping results cannot be taken to give a strong preference for  $J^\pi=0^+$  over  $J^\pi=2^+$ . The indirect evidence for a  $2^+$  assignment is that the  $C^{14}$  7.01-MeV level is the only known  $C^{14}$  level which could be the analog of the  $J^\pi=2^+$ ,  $T=1$ ,  $N^{14}$  9.17-MeV level and in turn there is no other known  $N^{14}$  level which could be a  $J^\pi=0^+$ ,  $T=1$  analog of the  $C^{14}$  7.01-MeV level. Thus, if the  $C^{14}$  7.01-MeV level is  $0^+$  and not  $2^+$  it means there is an undetected  $C^{14}$  level (with  $J^\pi=2^+$ ) near 7-MeV excitation and an undetected  $N^{14}$  level (with  $J^\pi=0^+$ ) near 9.2-MeV excitation. This seems quite unlikely.

One purpose of this investigation was to see what information could be obtained concerning nuclear lifetimes from measurement of the energy separation of close-lying pair lines. It is clear from the present results that a useful measurement of the relative Doppler shift of two lines can be obtained if the Doppler shift of one of the lines and the separation in excitation energy of the two lines are known from other work. However, the accuracy of this method is quite a bit less than in conventional Doppler shift measurements with scintillation crystal spectroscopy. The present method is of use, then, when conventional Doppler-shift techniques are not applicable. This would be true when the energy resolution of scintillation crystals was not adequate or in the study of  $E0$  transitions as in the present work on the  $C^{14}$  6.58  $\rightarrow$  0 transition.

#### ACKNOWLEDGMENTS

We would like to thank B. Cohen for sending us the  $C^{13}$  target and A. A. Jaffe, H. Marchant, S. Hinds, and L. F. Chase, Jr., for communications concerning their work on the energy levels of  $C^{14}$  and  $N^{14}$ .

## $Ne^{20}(p,p'\gamma)$ Angular Correlations at Low Energy

H. HULUBEI, N. MARTALOGU, M. IVASCU, N. SCINTEI, A. BERINDE, I. NEAMU, AND J. FRANZC

*Institute for Atomic Physics, Bucharest, Rumania*

(Received 18 April 1963)

$Ne^{20}(p,p'\gamma)$  1.63-MeV angular correlations have been measured in the 5.2–6.10 MeV energy range, where the elastic and inelastic excitation functions vary in a compensating manner. The measurements have been made at 5.25-, 5.55-, and 6.10-MeV proton energies, the position of the proton detector being at 60°, 90°, and 120°. One obtains strong angular correlation functions of the form  $A+B \sin^2(\theta-\theta_0)$ , where  $\theta_0$  defines the axis of symmetry. The angular correlation curves are insensitive to a change of the incident proton energy and  $\theta_0$  is situated in the proximity of the recoil direction  $\theta_R$  of the nucleus. These facts could constitute an argument in favor of the direct-interaction mechanism.

### I. INTRODUCTION

**I**N the last few years the  $(p,p'\gamma)$  angular correlation has been used several times for the study of reaction

mechanisms at low energy.<sup>1-8</sup> In these papers it is

<sup>1</sup> F. D. Seward, Phys. Rev. **114**, 514 (1959).

<sup>2</sup> H. A. Lackner, G. F. Dell, and H. J. Hausman, Phys. Rev. **118**, 1237 (1960).

shown that at bombarding energy less than 10 MeV, the two mechanisms of reaction, direct interaction (DI) and compound nucleus formation (CN), are in competition. The predominant mechanism depends on many factors, such as the bombarding energy, the Coulomb barrier height in comparison with the incident and emergent proton energy, the character of the excited level (collective or single-particle level), etc.

Litherland *et al.*<sup>9</sup> and Bouten<sup>10</sup> have shown in the case of Ne<sup>20</sup> that the low excited levels may be arranged in rotational bands and that we may expect a large cross section for the direct process.

The Ne<sup>20</sup>(p, p'γ) angular correlations, measured by Hausman, Dell, and Bowsher<sup>3</sup> at 7-MeV incident proton energy, are not in contradiction with the assumption that the inelastic scattering reaction of the 1.63-MeV first level excitation occurs through direct interaction.

In an earlier work,<sup>11</sup> carried out in our laboratory, on the angular distribution of elastic and inelastic ( $Q = -1.63$  MeV) scattering of protons from Ne<sup>20</sup> in the 5.2–6.23 MeV range of energy, relatively large values of the inelastic cross section were obtained, and it was shown that the excitation function of elastic and inelastic scattering varies in a compensating manner: To the maxima in the elastic scattering correspond the minima in the inelastic scattering, and conversely. An interpretation of these data was suggested involving the direct interaction theory with strong coupling which takes into consideration the coupling between the elastic and the inelastic scattering channels on the first excited state of the Ne<sup>20</sup>. The present work was undertaken to obtain some additional data for this interpretation.

## II. EXPERIMENTAL METHOD

The U-120 cyclotron of the Institute for Atomic Physics in Bucharest was the source of protons of energy 5.4, 5.7, and 6.2 MeV. The above-mentioned energies were evaluated by using the operating parameters of the cyclotron. The energy spread of the proton beam in the center of the target chamber was about 1%.

The proton beam was focused in the center of the

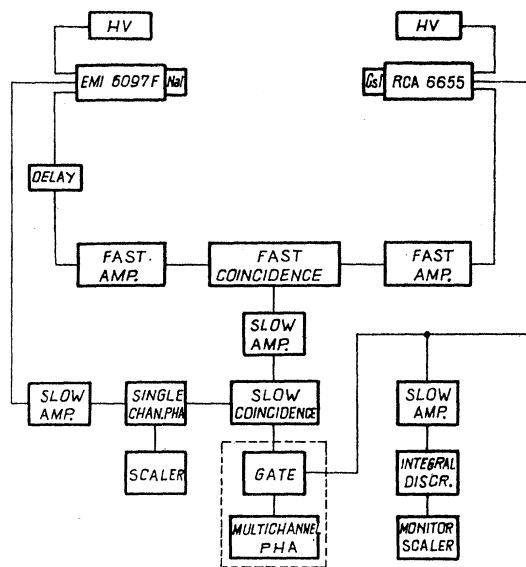

FIG. 1. Block diagram of the fast-slow coincidence circuit.

150-mm-diam scattering chamber. The cross section of the incident proton beam on the target was reduced to a 4-mm diameter by means of two tantalum collimators. To obtain accurately the desired energies in the correlation experiments, a disk with several holes covered by aluminum foils of different thicknesses was mounted between the collimators. The position of the foils was changed by rotating the disk by means of a selsyn motor. The gas target chamber was mounted in the center of the scattering chamber. It was made by a 6-cm-diam and a 6-cm-high brass cylinder with two lateral windows, each 1.2 cm high with a 145° opening covered by a Mylar foil of thickness 10 μ. During the experiments the neon pressure was maintained at 200 mm Hg. The scattering chamber was provided with four mobile arms. The proton detector, consisting of a RCA-6655A photomultiplier and a CsI(Tl) 0.08-cm-thick crystal, was mounted on one of the four arms. In front of the proton detector was mounted a tantalum collimator to define the solid angle necessary in the experiments with a gas target. The γ detector consisted of an EMI-6097 F photomultiplier and a 3.8-cm-diam and a 2.5-cm-high NaI(Tl) crystal fixed on the other arm. Both counters were shielded by lead to decrease the γ-ray background.

The proton detector was situated at 21 cm from the center of the gas chamber and the γ detector at a distance of 9.5 cm.

In Fig. 1 the block diagram of the fast-slow coincident circuit used in the correlation measurements is shown. The fast pulses from the scintillation counters are amplified and introduced into a fast coincident circuit with a 26-nsec resolving time. The pulse from the fast coincident circuit is amplified and introduced into a slow coincident circuit, in coincidence with a γ slow

<sup>3</sup> H. J. Hausman, G. F. Dell, and H. F. Bowsher, Phys. Rev. **118**, 1237 (1960).

<sup>4</sup> H. Yoshiki and N. Nicolici, Nucl. Phys. **19**, 442 (1960).

<sup>5</sup> H. F. Bowsher, G. F. Dell, and H. J. Hausman, Phys. Rev. **121**, 1504 (1961).

<sup>6</sup> B. Gobbi and R. E. Pixley, Helv. Phys. Acta **34**, 802 (1961).

<sup>7</sup> H. Taketani and W. P. Alford, Nucl. Phys. **32**, 430, (1962).

<sup>8</sup> H. Hulubei, N. Martalogu, J. Frantz, M. Ivascu, N. Scinte, A. Berinde, and I. Neamu, Phys. Rev. **126**, 2174 (1962).

<sup>9</sup> A. E. Litherland, J. A. Kuehner, H. E. Gove, M. A. Clark, and E. Almqvist, Phys. Rev. Letters **7**, 98 (1961).

<sup>10</sup> M. Bouten, Nuovo Cimento **26**, 63 (1962).

<sup>11</sup> H. Hulubei, A. Berinde, I. Neamu, J. France, N. Martalogu, and M. Ivascu, Nucl. Phys. **39**, 686 (1962).

<sup>12</sup> S. Yoshida, Progr. Theoret. Phys. (Kyoto) **19**, 163 (1958).

<sup>13</sup> C. B. O. Mohr, Proc. Phys. Soc. London, **73**, 894 (1959); **78**, 641 (1961).

<sup>14</sup> S. Okaj and T. Tamura, Nucl. Phys. **31**, 185 (1962).

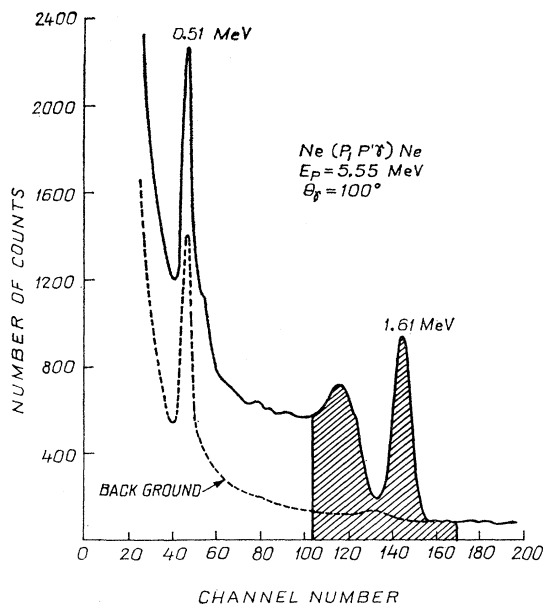

FIG. 2. The gamma-ray spectrum at 5.5-MeV proton bombarding energy from neon gaseous target. The dashed curve represents the gamma background from the unfilled neon gaseous target chamber. The hatched area indicates the part of the gamma spectrum used in the coincidence measurements.

pulse. The exit of this slow coincident circuit controls the gate of the SA-40 pulse-height analyzer, at whose entrance pulses arrive from the proton detector, thus insuring the recording of the proton spectrum in coincidence with the  $\gamma$  ray.

To decrease the number of random coincidences produced by the  $\gamma$  background of the cyclotron and by the  $\gamma$  rays of the Mylar foil, slow pulses from the  $\gamma$ -ray detector were applied to a single-channel pulse-height analyzer with the window adjusted to pass only the pulses corresponding to the 1.2–1.8 MeV interval.

In Fig. 2, a typical  $\gamma$ -ray spectrum is shown, corresponding to a  $100^\circ$  angle of the  $\gamma$  detector.

The hatched part indicates the region of the spectrum used in the coincidence measurements. The random coincidence determination was made, using the coincident and the noncoincident proton- $\gamma$  ray spectrum. In Fig. 3 two of these spectra are shown, corresponding to the 5.55-MeV incident proton energy. Since the elastically scattered protons cannot give actual coincidences, the elastic peak from the coincident proton spectrum is interpreted as being produced by the random coincidences only. Let  $N_i$  and  $N_e$  be the number of pulses corresponding to the elastic and the inelastic peaks in the noncoincident spectrum, and  $N_{ae}$  the number of pulses corresponding to the elastic peak of the coincident proton spectrum. The number of accidental coincidences  $N_{ai}$  of the inelastic peak will then be given by

$$N_{ai} = N_{ae} N_i / N_e.$$

In our correlation measurements the ratio of the

actual and accidental coincidences varied between 2:1 and 12:1. The measurements were made with the proton detector fixed at each of the angles  $60^\circ$ ,  $90^\circ$ , and  $120^\circ$  and the gamma detector was moved in the  $30^\circ$ – $140^\circ$  angular interval in steps of  $10^\circ$ . The monitoring was made by recording a fixed number of elastically and inelastically scattered protons for each position of the gamma detector.

### III. RESULTS

In a recent paper,<sup>11</sup> it was shown that the  $\text{Ne}^{20}(p, p')$  angular distribution presents a compensating variation of the elastic and inelastic scattering cross sections. In Fig. 4 the excitation functions of the total inelastic and integrated differential elastic cross section from  $60^\circ$  to  $180^\circ$ , obtained in the above paper, are shown. The arrows indicate the energies at which the correlation measurements were made. The choice of the energies was made so as to show the behavior of the angular correlation function when the measurements are made at the various maxima and minima of the excitation function. The results of the angular correlation measurements are shown in Figs. 5–7. The statistical errors are indicated for each point. Each correlation curve represents the result of three runs. The angles of the

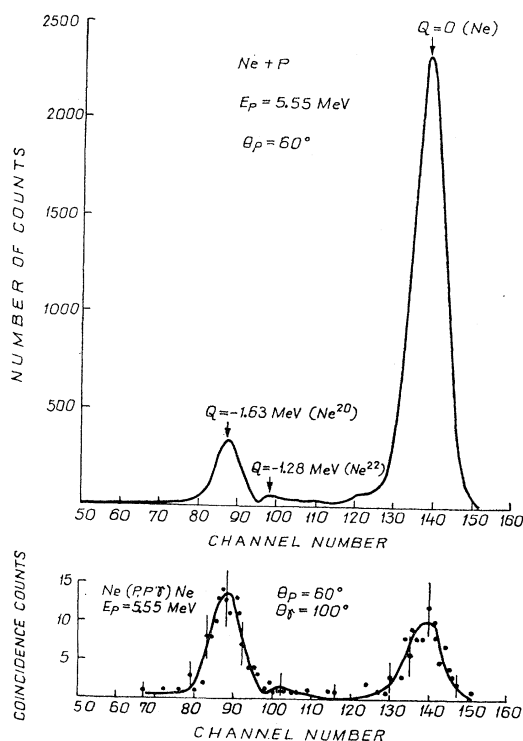

FIG. 3. In the upper part of the figure the spectrum of the protons scattered by the neon target at 5.5-MeV bombarding energy and at a  $60^\circ$  angle is shown. In the lower part, the spectrum of the protons in coincidence with the  $\gamma$  rays comprised in the hatched area of Fig. 2 is shown. In this case the ratio of the real and accidental coincidences is 10:1.

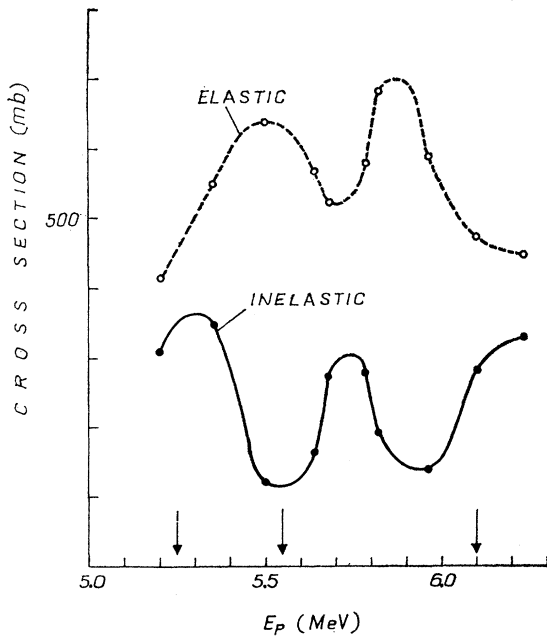

FIG. 4. The excitation functions of the total inelastic and integrated differential elastic cross section from 60° to 180° in the Ne<sup>20</sup>+p reaction.

gamma detector were traversed at random, to average the possible shifts of the electronic circuit and the intensity variation of the incident beam which occur over a long period of time. The curves  $A + B\sin^2(\theta - \theta_0)$  represent the least-squares fit of the experimental points. The correlation functions were corrected by taking into consideration the solid angle of the gamma detector.<sup>15</sup>

The angle corresponding to the recoil direction of the nucleus is  $\theta_R$  and  $\theta_0$  represents the symmetry axis of the measured correlation curves.

Our correlation results are similar to those obtained from Ne<sup>20</sup> by Hausman, Dell, and Bowsher<sup>3</sup> at 7-MeV energy. A feature of these curves is the strong correlation expressed by a large value of the  $B/A$  ratio and also the stability of their shape and position for changes of energy. Likewise, it should be noticed that the symmetry axis for the 60° and 90° angles of the proton detector is situated in the proximity of the recoil direction of the nucleus, whereas  $\theta_0$  for the curves corresponding to the 120° proton detector position differs to a greater extent from  $\theta_R$ . Generally one can, however, ascertain that the symmetry axis tends to change its position in the direction of displacement of the recoil axis of the nucleus.

IV. CONCLUSIONS

The angular correlation data could be represented well enough by the function  $A + B\sin^2(\theta - \theta_0)$  forecast by

<sup>15</sup> M. E. Rose, Phys. Rev. **91**, 610 (1953).

the distorted-wave DI theory.<sup>16</sup> Although the angular correlation curves measured have little sensitivity to the angular variation of the proton detector, they also have little sensitivity to the energy change. The experimental data do not show marked changes when passing from a maximum of the excitation curve to another maximum or from a maximum to a minimum. The angular correlation curves which are loosely dependent on the incident proton energy could eventually be interpreted on the basis of the CN statistical model.

Concerning this point, however, we mention that the recent computations of Sheldon<sup>17</sup> on the basis of the statistical model could not realize a fit with Hausman, Dell, and Bowsher's correlation data for Ne<sup>20</sup>(p, p'γ) at 7-MeV energy and it is not likely that the fit may be reached at the energies at which we worked.

The angular correlation curves corresponding to some single resonances or to a group of resonances in the

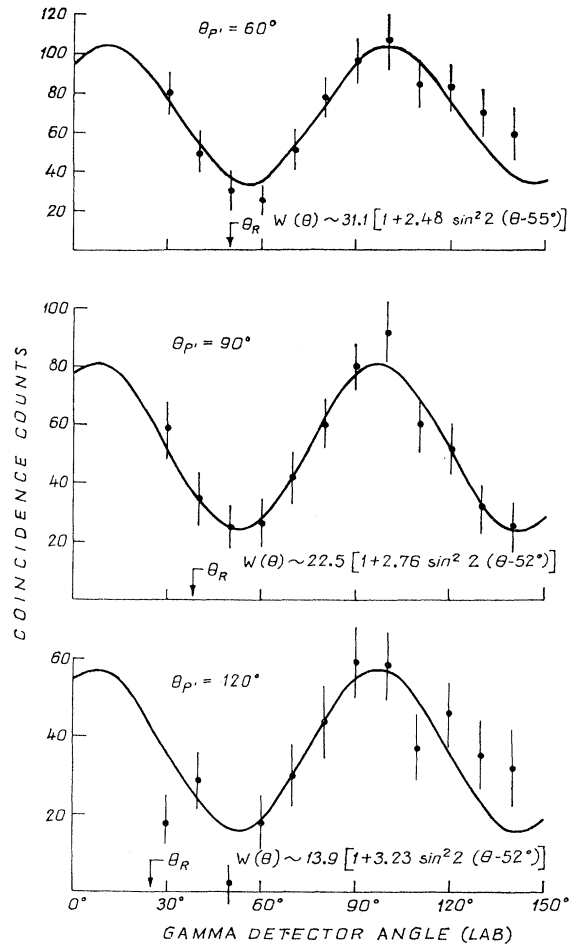

FIG. 5. Ne<sup>20</sup>(p, p'γ) angular correlation at incident beam energy of 5.25 MeV.  $\theta_R$  is the nuclear recoil direction.

<sup>16</sup> G. A. Levinson and M. K. Banerjee, Ann. Phys. (N. Y.) **2**, 499 (1957); **3**, 67 (1958).

<sup>17</sup> E. Sheldon (private communication).

compound nucleus could present strong variations when one passes from one resonance to another or when one works at an energy outside resonance. It is, therefore, difficult to draw the conclusion that the compound nucleus processes could explain the observed angular correlation. Conversely, the theoretical calculation of the  $p'-\gamma$  angular correlation using the distorted-wave DI formalism carried out by Levinson and Banerjee<sup>16</sup> shows a lack of sensitivity of the symmetry axis  $\theta_0$  to the

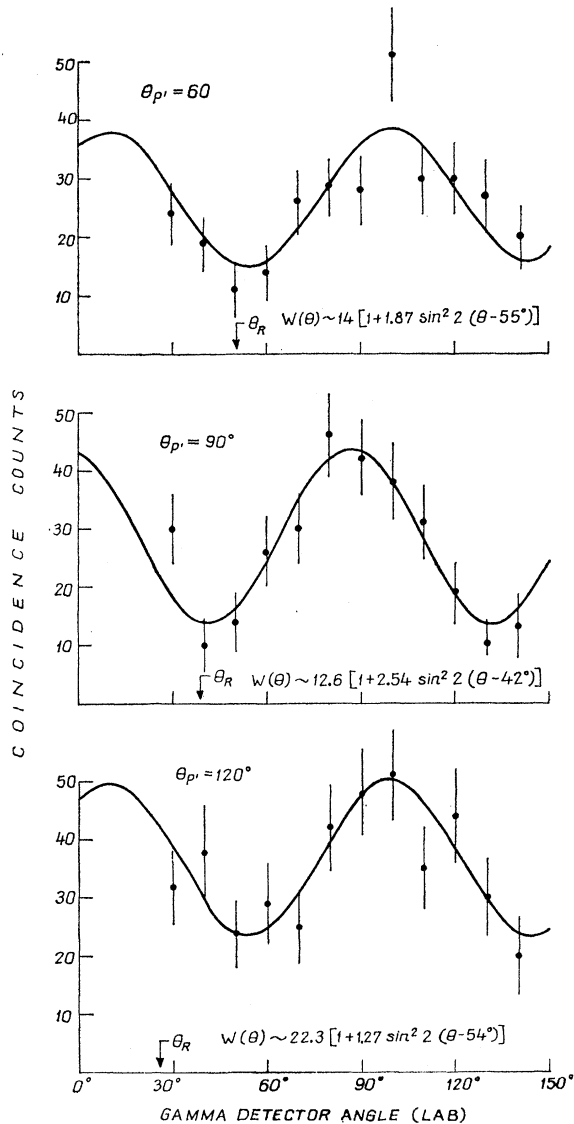

FIG. 6.  $\text{Ne}^{20}(p, p'\gamma)$  angular correlation at incident beam energy of 5.55 MeV.  $\theta_R$  is the nuclear recoil direction.

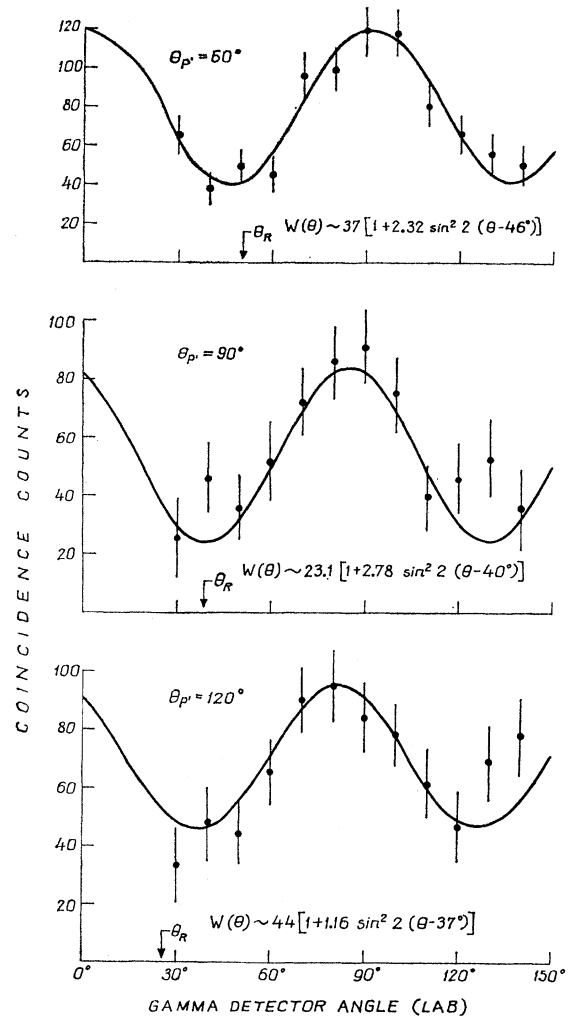

FIG. 7.  $\text{Ne}^{20}(p, p'\gamma)$  angular correlation at incident beam energy of 6.10 MeV.  $\theta_R$  is the nuclear recoil direction.

incident proton energy variation. The fact that the symmetry axis does not strictly follow the recoil direction of the nucleus according to the theoretical simple DI forecast is probably due to the presence of some strong distortions of the incident and emergent waves at low energy.

#### ACKNOWLEDGMENTS

The authors express their grateful appreciation to Dr. Eric Sheldon for sending them his computations of angular correlation before they were published. They also thank the cyclotron staff and Mrs. S. Lupescu and I. Hustea for their technical assistance.